



VIGNAN'S INSTITUTE OF MANAGEMENT AND
TECHNOLOGY FOR WOMEN

Environmental Audit
(Water & Waste Management)

CONTENTS

04 Acknowledgement

05 Executive Summary

07 Environmental Audit

08 Water & Waste Management

09 Recommendations

20 Conclusion



PRINCIPAL

Vignan's Institute of Management & Technology For Women
Kondapur (V), Ghatkesar (M), Medchal-Malkajgiri (Dt)-501301
Telangana State

Acknowledgements

REST Pvt Ltd

Dr Rekhapalli Srinivasa Rao
Green, Eco & Energy Lead Auditor
Certified ISO-14001 Auditor

20 Dec 2021

Environmental Audit (Water & Waste Management)

The REST Pvt Ltd acknowledges with thanks the cooperation extended to our team for completing the study at Vignan's Institute of Management and Technology for Women (VMTW).

The interactions and deliberations with VMTW team were exemplary and the whole exercise was thoroughly a rewarding experience for us. We deeply appreciate the interest, enthusiasm, and commitment of VMTW team towards environmental sustainability.

We are sure that the recommendations presented in this report will be implemented and the VMTW team will be further improve their environmental performance.

Kind regards

Your sincerely



Dr Rekhapalli Srinivasa Rao
Green, Eco & Energy Lead Auditor
Certified ISO-14001 Auditor
REST Pvt Ltd

PRINCIPAL
Vignan's Institute of Management & Technology For Women
Kondapur (V), Ghatkesar (M), Medchal-Malkajgiri (Dt)-501301
Telangana State

Executive Summary

The growth of countries across the world is leading to increased consumption of natural resources. There is an urgent need to establish environmental sustainability in every activity we do. In a modern economy, environmental sustainability will play a critical role in the very existence of an organization.

An educational institution is no different. Built environment, especially an educational institution, has a considerable footprint on the environment. Impact on the environment due to energy consumption, water usage and waste generation in an educational institute is prominent. Therefore, there is an imminent need to reduce the overall environmental footprint of the institution.

As an Institution of higher learning, Vignan's Institute of Management and Technology for Women (VMTW) firmly believes that there is an urgent need to address the environmental challenges and improve their environmental footprint.

True to its belief, VMTW has installed solar panel and implemented rainwater harvesting in the campus. Continuing with rainwater harvesting, the college can also investigate the following recommendations:

- **Attain water positive status:** VMTW should focus on capturing the harvested rainwater to substitute freshwater consumption, work on sustainable groundwater beyond the fence and create a framework towards attaining water positive status over a period. Presently, VMTW is consuming nearly 5000 lt of fresh water per day. Since metering is not available, the water consumption is calculated rather than measure value. The first step is to increase the water conservation activities in the campus to reduce water consumption at source. The next step is to increase the rainwater harvesting capacity to completely offset the freshwater requirements of the plant. VMTW can also explore adopting lakes, desilting of ponds and restoration of water bodies in localities surrounding the campus. Water getting harvested in those structures can offset the freshwater consumption of the college.
- **Install water efficient fixtures:** The best way to conserve water is at the source. Therefore, VMTW will have to install water efficient fixtures to reduce water consumption. Some of the water efficient fixtures are:
 - Waterless urinals
 - Electronic taps (e-taps)
 - Electronic flush urinals (e-flush)
 - Foam taps
 - Spring loaded push taps
 - Low flush cistern
- **Install sewage treatment plant / rootzone treatment:** VMTW uses more than 5000 lt of fresh water per day. Considering that 3000 lt (least value) of water is being let to drain without



PRINCIPAL
Vignan's Institute of Management & Technology For Women
Kondapur (V), Ghatkesar (M), Medchal-Malkajgiri (Dt)-501301
Telangana State

treatment, good opportunity exists to reduce freshwater consumption by treating the sewage water and using the recycled water for gardening and flushing application. Install biogas plant and phytoremediation in series to recycle water and reduce freshwater consumption.

- **Install water flow meters:** Water flow meters are vital in understating the water consumption patterns of the campus. Presently, the water consumption is calculated rather than being measured. Water flow meters gives an accurate status if water consumption in the campus and from the water consumption values, the roadmap for water conservation activities can be prepared.

- **Segregate waste at source:** VMTW has provided bins for waste collection. VMTW must embark on awareness creation methods to increase the effectiveness of collection and provide more bins for proper waste segregation.

- **Maintenance of waste management yard:** The waste management yard is to be maintained just like raw materials storage room. Waste is nothing but a resource in wrong place. Therefore, by maintaining the waste management yard, quality of wastes can be maintained.



PRINCIPAL
Vignans Institute of Management & Technology For Women
Kondapur (V), Ghatkesar (M), Medchal-Malkajgiri (Dt)-501301
Telangana State

Environmental Audit

VMTW and REST are working together to identify opportunities for improvement in water management, and waste management. This report highlights all the potential proposals for improvement through the audit and analysis of the data provided by VMTW for water consumption and waste management. The report details the process conducted for the analysis such as on ground surveys performed for listing the type of water consumers with consumption per year, types of waste generated and disposal mechanisms.

Submission of Documents

Environmental audit at VMTW was carried out with the help data submitted by VMTW team. VMTW team was responsible for collecting all the necessary data and submitting the relevant documents to REST Pvt Ltd for the study.

Preliminary Study

After the receipt of documents, a desktop review of the data for quality check, followed by preliminary study was carried out by REST Pvt Ltd. In case of discrepancy/inadequacy/non-clarity of data, REST Pvt Ltd team got in touch with the VMTW team for clarification/additional information.

Environmental Audit

Data submitted and collected during the visit was used to assess the water and waste management practices of the campus and finally provide necessary recommendation for environmental improvement.

Note

Environmental audit is based on the data provided by VMTW team. The scope of the study does not include the exclusive verification of various regulatory requirements related to environmental sustainability.

REST Pvt Ltd has the right to recall the study, if it finds (a) major violation in meeting the environmental regulatory requirements by the location and (b) occurrence of major accidents, leading to significant damage to ecology and environment.



PRINCIPAL

Vignan's Institute of Management & Technology For Women
Kondapur (V), Ghatkesar (M), Medchal-Malkajgiri (Dt)-501301
Telangana State

Water Conservation

To achieve a water positive status by continuous reduction of freshwater consumption should be the ultimate focus of VMTW. Increased and focused attention should be given to attain water sustainability in future by inculcating the discipline of water conservation.

Fresh water consumption of VMTW : 5000 It per day

Rainwater harvesting : Carried out for roof area

According to the report, 'Water in India: Situation & Prospects', India is the largest consumer of groundwater in the world with an estimated usage of 230 km³ per year. Approximately 60 per cent of the demand from agriculture and irrigation, and about 80 per cent of the domestic water demand, is met through groundwater. As per the Department of Drinking Water and Sanitation nearly 90 per cent of the rural water supply is from groundwater sources. This has led to an increased pressure on aquifers and the resulting hydrological imbalance.





PRINCIPAL
Vignan's Institute of Management & Technology For Women
Kondapur (V), Ghatkesar (M), Medchal-Malkajgiri (Dt)-501301
Telangana State

Recommendations for water conservation

1) Waterless urinals: Waterless urinals look like regular urinals without a pipe for water intake. Men use them normally, but the urinals don't flush. Instead, they drain by gravity. Their outflow pipes conduits to a building's conventional plumbing system. In other words, unlike a composting toilet, which leaves you to deal with your waste, these urinals send the urine to a water treatment plant.

- a. Urine flows into the drain insert of the EcoTrap.
- b. Inside of the EcoTrap the urine moves through a floating layer of proprietary immiscible Blue Seal liquid, which creates a barrier, preventing sewer gases and urine odours from entering the restroom area.
- c. The urine below the Blue Seal barrier overflows into the central tube and travels down into the drain line.

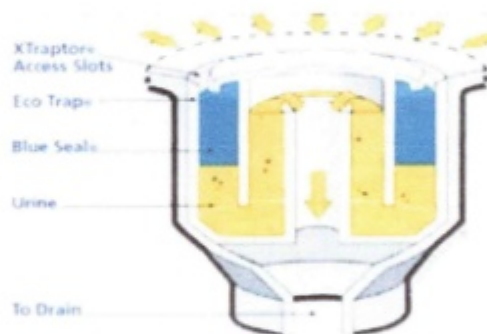
Waterless Urinal



d. Approximately 1500 sanitary uses are possible with just 3 ounces of BlueSeal. When the BlueSeal liquid is gone, it is simply replenished. This only takes about 20 seconds to perform and the EcoTrap is not touched.

e. Urine sediments are retained within the EcoTrap. Replacement is easy and need only be done 2 to 4 times per year depending on traffic to the urinal. As tool called the X-Traptor must be used to remove the EcoTrap. The use of the special tool helps to minimize vandalism. The entire process of replacement only takes 3 to 4 minutes.



Vignan
PRINCIPAL
Vignan's Institute of Management & Technology For Women
Kondapur (V), Ghatkesar (M), Medchal-Malkajiri (Dt)-501301
Telangana State

Waterless urinals are available for women. Indian manufacturers are supplying waterless urinals technology. Ekameco is one such company providing solution for women waterless urinals. You may visit www.ekameco.com and mail info@ekameco.com for more details on waterless urinals for women.

2) Volume reduction in flush tanks: One simple method is to add a one-liter equivalent water bottle in the flush tank thereby reducing its consumption majorly. One-liter savings in the tank will help to save approximately by 20% and doesn't require any investment.



3) Rainwater harvesting: Water harvesting or more precisely rainwater harvesting is the technique of collection and storage of rainwater at surface or in subsurface aquifer, before it is lost as surface run off. In artificial recharge, the ground water reservoirs are recharged at a rate higher than natural conditions of replenishment. According to a report by the Central Groundwater Board published in 2007, the selection of a suitable technique for artificial recharge of ground water depends on various factors. They include:

- a) Quantum of non-committed surface runoff available
- b) Rainfall pattern
- c) Land use and vegetation
- c) Topography and terrain profile
- d) Soil type and soil depth
- e) Thickness of weathered / granular zones
- f) Hydrological and hydrogeological characteristics
- g) Socio-economic conditions and infrastructural facilities available
- h) Environmental and ecological impacts of artificial recharge scheme proposed



PRINCIPAL
Vignani's Institute of Management & Technology For Women
Kondapur (V), Ghatkesar (M), Medchal-Malkajgiri (Dt)-501301
Telangana State

Rainwater Harvesting Techniques in Urban Area

In urban areas rainwater is available from roof tops of buildings, paved and unpaved areas. This water could be stored and used to replace freshwater as well as used for recharging the aquifer.



4) Display water balance/conservation status at entrance of all blocks for overall involvement of all students & staff.

It is suggested to display specific water consumption numbers in terms of domestic use at the entrance of each blocks to create awareness among all students and stakeholders visiting the facility. This daily/continuous awareness creation will ultimately help in reduction of water consumption by students.



[Signature]
PRINCIPAL
Vignani's Institute of Management & Technology For Women
Kondapur (V), Ghatkesar (M), Medchal-Malkajgiri (DI)-501301
Telangana State

Water Saving Gadgets

It is suggested to display specific water consumption numbers in terms of domestic use at the entrance of each block to create awareness among all students and stakeholders visiting the facility. This

Electronic Taps (e-taps)

The latest trend in industries is to install electronic taps (e-taps). The advantages of using e-taps are as mentioned below:

- Unlike conventional taps, there is no twisting or turning in e-taps. They have a sensor, which cuts off water supply completely when not in use. This helps in saving up to 70% water during hand wash.

E-taps enable hands free operation. No fear of cross contamination or contact with germs. E taps score very high on hygiene. It is the most ideal choice for multipurpose and multi-user washrooms.

- E-taps can work efficiently up to raw water TDS of 1,800 ppm.

The touch free electronic taps, available in AC and DC models consume minimal power only. The AC model has an efficient battery back-up, while the DC model runs on just 4 alkaline batteries.

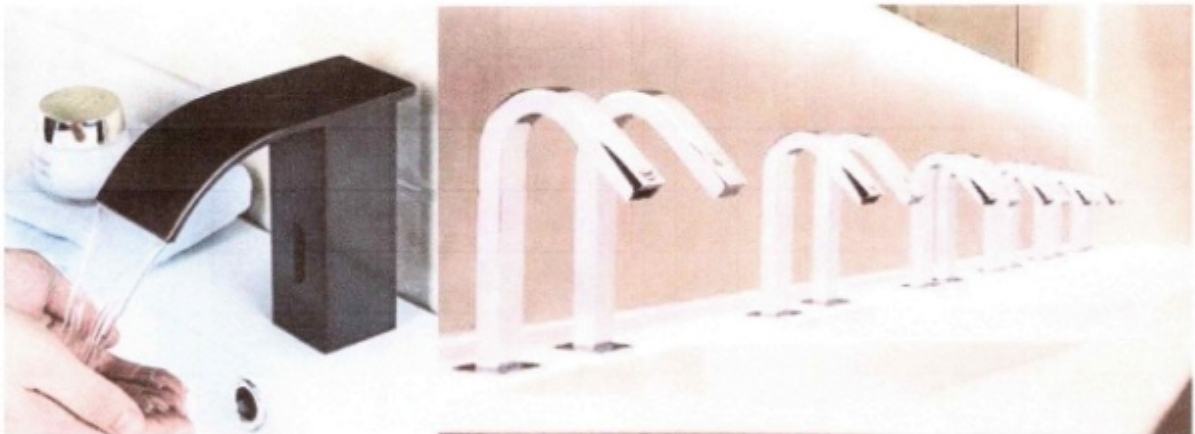

Operation of Electronic Taps

This has been successfully implemented in several hotels & restaurants. Of late, several industries have also started implementing this proposal. Thus, there is a good potential to optimize the Fresh water consumption by replacing the existing taps with e-taps.



PRINCIPAL
Vignani's Institute of Management & Technology For Women
Kondapur (V), Ghatkesar (M), Medchal-Malkajgiri (Dt)-501301
Telangana State

Electronic flush (e-flush) urinals

The latest trend in industries is to install e-flush urinals. The advantages of using e-flush urinals are as mentioned below:

- E-flush urinals are fitted with a sensor, which senses the usage and flush with water for few seconds after use. This helps in saving 70% water during urinal flush.
- E-flush urinals enable hands-free operation and score very high on hygiene. It is the most ideal choice for multipurpose and multi-user washrooms.
- E-flush urinals can work efficiently up to raw water TDS of 1,800 ppm.
- The touch free e-flush urinals available in AC and DC models consume minimal power only. The AC model has an efficient battery back-up, while the DC model runs on just 4 alkaline batteries.

Electronic flush urinals



Hand wash

Foam taps

Conventional taps are used in the hand wash areas which results in wastage of large quantities of fresh water. Foam taps are a better fit in these high consumption areas. They consume 25-30% less water than conventional taps.

Foam taps



PRINCIPAL
Vignani's Institute of Management & Technology For Women
Kondapur (V), Ghatkesar (M), Medchal-Malkajgiri (DI)-501301
Telangana State

Spring loaded Push taps

Spring loaded push type tap is an alternate device for minimizing hand wash water. The spring-loaded push taps operate with the simple mechanism of pressing the knob for water. The knob is automatically released back to close position in 5-7 seconds. This saves about 30-40% of water compared to the conventional taps.

Spring loaded push taps



Low flush cistern

The latest model closets are water efficient and operate in dual mode, with a single flush releasing 2 litres of water and the dual flush releasing 4 litres per flush. This results in excellent water savings.

Low flush cisterns



Install sewage treatment plant - Rootzone treatment:

VMTW uses more than 200 KL of fresh water per day. Considering 150 KL of water is being let to drain without treatment, good opportunity exists to reduce freshwater consumption by treating the sewage water and using the recycled water for gardening and flushing application. Install biogas plant and phytoremediation in series to recycle water and reduce freshwater consumption.





PRINCIPAL
Vignan's Institute of Management & Technology For Women
Kondapur (V), Ghatkesar (M), Medchal-Malkajgiri (DI)-501301
Telangana State

Presently, sewage water is being let out to the drain without treatment. An opportunity exists to generate biogas from the untreated sewage water and use the generated biogas to substitute LPG used (10cylinders/year) in the college.

Biogas Production Potential of Wastewater

The sewage water is a useful waster as 1% of it in any quantity is a sludge which when subjected to anaerobic digestion will produce biogas. Wastewater is the effluent from household, commercial establishments and institutions, hospitals, industries and so on. Sewage water source contains large amount of organic material which can be efficiently recovered in as sludge which and when subjected to anaerobic digestion, the sludge produces methane gas (biogas).

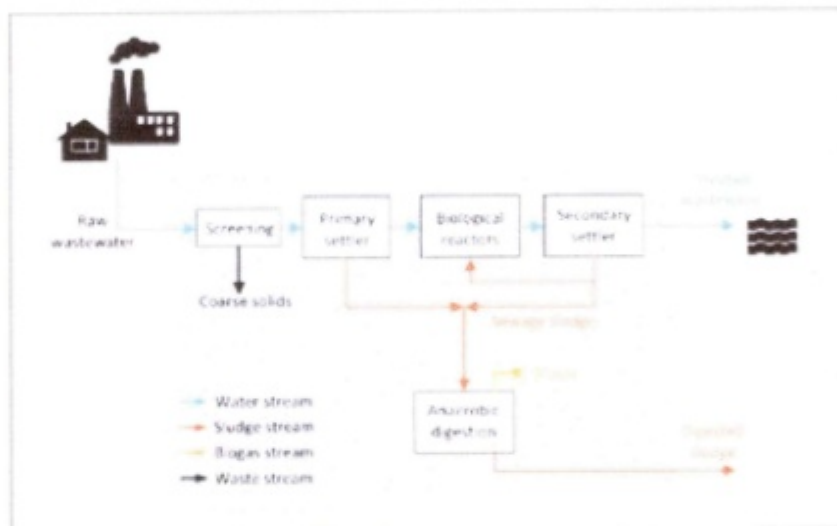
Biogas is a mixture of gases containing 50-75% Methane, and 25-50% Carbon dioxide while 0-10% Nitrogen, 0-3% Hydrogen disulphide and 0-2% Hydrogen may be present as impurities which is produced by anaerobic digestion of organic material i.e. a sequential enzymatic breakdown of biodegradable organic



material (Biomass) in the absence of oxygen. The process is usually carried out in a digester tank known as biodigester. Biogas is an important energy source used as cooking gas, to generate electricity, etc. thus producing biogas from wastewater is an efficient and sustainable waste management and renewable energy technique. One of the major environmental problems of the world today is waste management and wastewater constitutes a huge environmental problem to the society thus the need for wastewater treatment to recover and also recycle the recovered water for usage.

The physical process: this is the mechanical treatment of the water that involves removal of debris from the raw wastewater right from the point it enters the plant. The screening and primary settling of debris. Wastewater enters the treatment plant through the inlet chamber from where it is channelled to the coarse screen that removes solid waste.

The biological process: this involve the biotreatment of the sewage in the bioreactors. It is the heart of the treatment plant where a biological process takes place. The bioreactors of a treatment plant are usually large tanks consisting of several mammoth rotors and submersible mixers. While the rotor introduces atmospheric oxygen into the sewage, the submersible mixers keep the biomass in suspension thus several reactions take place in the bioreactors.



Principal
 PRINCIPAL
 Vignan's Institute of Management & Technology For Women
 Kondapur (V), Ghatkesar (M), Medchal-Malkajgiri (Dt)-501301
 Telangana State

From the bioreactor, the sewage enters the sedimentation tank. Here the biological process ends and sludge is separated from water such that the clean water is passed to the disinfection tank for disinfection and onward discharge for use while the sludge is removed by the returned activation sludge (RAS) pump that removes and sends part to the anaerobic digestion chamber while some e return to the anaerobic bioreactor for reactivation.

Production of biogas is an anaerobic digestion whereby microorganisms break down biodegradable material in the absence of oxygen to produce methane/carbon dioxide used to generate electricity and heat. Sludge from the treatment plant (primary and activated sludge) is the main feedstock (biodegradable organic matter) in the biogas production plant of a wastewater treatment plant and the biogas production process involves series of steps. The combine sludge resulting from primary and secondary water treatment is gathered, sieved and thickened to a dry solids content of up to 7% before entering the digesters. Optionally, the sludge can be pre-treated by disintegration technologies with the aim to improve the gas yield. In the anaerobic digestion process, the sludge is pumped into the anaerobic continuously stirred tank reactors where digestion takes place. In the process, microorganisms break down part of the organic matter that is contained in the sludge and produce biogas, which is composed of methane, carbon dioxide and trace gases. The raw biogas produced is dried and hydrogen sulphide and other trace substances removed and burned in burners after treatment. The digested sludge is dewatered, and the water reintroduce into the treatment plant while the remaining undigested matter used for organic fertilizer.

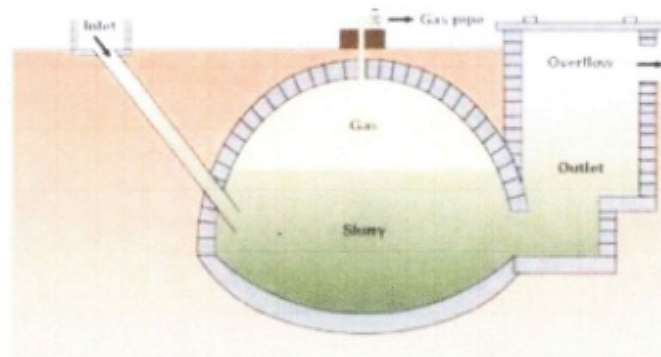

Rootzone treatment:

Root Zone' is a scientific term used to cover all the biological activity among different types of microbes, the roots of plants, water soil and the sun. It consists planted filter-beds containing ravel, sand and soil. The RZWT system utilises nature's way of biologically processing domestic & industrial effluents. This effective technology called Decentralised Wastewater Systems (DEWATS) was developed in 1970s in Germany and has been successfully implemented in different countries mainly in Europe and America.

The root zone wastewater treatment system makes use of biological and physical-treatment processes to remove pollutants from wastewater. Due to its natural process, there is no need to add any input such as chemicals, mechanical pumps or external energy. This reduces both the maintenance and energy costs.



[Handwritten Signature]
PRINCIPAL
Vignans Institute of Management & Technology For Women Page 16
Kondapur (V), Ghatkesar (M), Medchal-Malkajgiri (DI)-501301
Telangana State

- To accomplish this, the root zone wastewater treatment undertakes the following steps:
- Pre-treatment done in a Settler - a device that separates the liquid from the solid First treatment takes place in an Anaerobic Baffled Reactor - a device with several identical chambers through which the effluent moves from top to bottom.
- Second treatment happens in an Anaerobic Filter - a device filled with a filter material (cinder), through which the effluent moves from top to bottom.

Third treatment takes place in a Planted Gravel Filter - a structure filled with gravel material and planted with water-resistant reed plants, which provide oxygen to the passing effluent.

The Root Zone Wastewater Treatment system takes into account the natural slope of the ground, so that water flows from one device to another without any ternal energy input such as motor pump. Once the reed plants create an established stand, usually after the first growing season, the reed bed requires little or no maintenance. The plant foliage will soon blend naturally into the landscape, ever changing with the seasons and creating a pleasing sight as well!



Install water flow meter:

Water flow meters are vital in understating the water consumption patterns of the campus. Presently, the water consumption is calculated rather than being measured. Water flow meters gives an accurate status if water consumption in the campus and from the water consumption values, the roadmap for water conservation activities can be prepared.

Water Meters would have many advantages:

- Encourage water conservation - important given strain on water resources
- Encourage allocatively efficient distribution. People would consume to where the marginal cost = marginal utility



RAA
 PRINCIPAL
 Vignani's Institute of Management & Technology
 Kondapur (V), Ghatkesar (M), Medchal-Malkajgiri (D), 501301
 Telangana State

- In long term lower overall water consumption would reduce leading to even lower water bills.

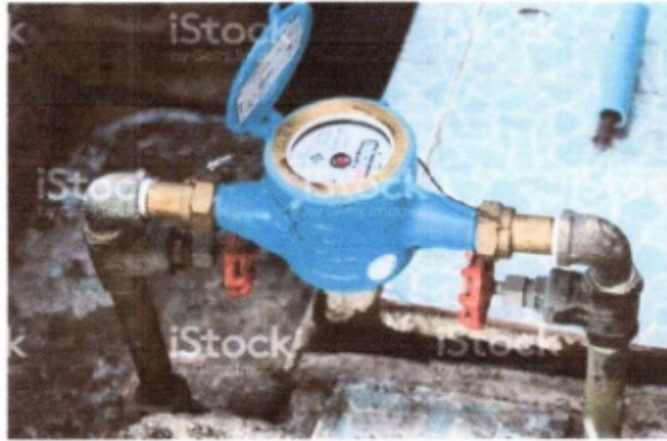

ASh
PRINCIPAL

vignan's Institute of Management & Technology
Kondapur (V), Ghatkesar (M), Medchal-Malkajgiri (Dt)-501301
Telangana State



Waste Management

India has drawn world's attention with its high paced urbanization and industrialization. Over the last decade, India has emerged as the fastest growing country with rapid economic growth. A renewed focus on sustainable growth and development is imperative as India strives to maintain its high GDP growth rate in its pursuit of achieving developed country status by the year 2022. However, the flip side of higher economic growth has resulted in increased consumption of the natural resources, increased waste generation and hence ecological degradation.

Present status: VMTW has initiated waste management activities inside its facility. Separate bins have been provided (dry and wet waste) for different types of wastes. Waste bins are provided throughout the campus and students are being urged to use the bins effectively.

Recommendation: The waste management yard must be maintained in a similar fashion as that of a raw material storage room. Therefore, a total revamp of the waste storage yard is to be carried out. By doing so, the quality of the materials stored in the yard will not deteriorate and can be used as a raw material for a subsequent process.

Enhance awareness creation, training and capacity building.

VMTW should focus on implementing sustainable waste management practices. VMTW should regularly interact with Pollution Control Board and TSDF operators to enhance knowledge on waste management. The team should also take efforts to communicate the waste management and other policies and activities to all students in the college.

Achieve zero liquid discharge status:

VMTW may install a STP to treat and recycle water. The treated water from STP can be used to substitute freshwater by utilizing the treated water in both high end and low-end applications.



PRINCIPAL

Vignans Institute of Management & Technology For Women
Kondapur (V), Ghatkesar (M), Medchal-Malkajgiri (Dt)
Telangana State

Conclusion

Environmental sustainability is a continuous process and there is always a scope for improvement. VMTW has displayed itself as an advocate of environmental sustainability by getting environmental audit carried out. The organization has implemented several initiatives and measures to enhance efficiency and to optimize resource intensity. The journey ahead in the path towards environmental excellence has immense scope for improvement as brought out by this report.

VMTW needs to focus and work on areas efficiency levels needs to be enhanced. For example: waste management. The observations and suggestions put forth by the report would help the facility in improving its environmental performance and pave way for ecologically sustainable growth.

This report may be taken as a guide and roadmap for achieving higher performance rating in environmental stewardship. As one of the pioneers and leaders VMTW shoulder the task of further 'learning-teaching-learning' to improve, excel, and continue the innovative efforts for success of their students and associates.

PRINCIPAL

Vignani's Institute of Management & Technology For Women
Kondapur (V), Ghatkesar (M), Medchal-Malkajgiri (Dt)-501301
Telangana State



CERTIFICATE OF COMPLETION

This is to certify that

Vignan's Institute of Management and Technology for Women

has successfully completed

ENVIRONMENTAL AUDIT

(WATER & WASTE MANAGEMENT)

The study was completed by Rekhapalli Environmental Solutions & Technologies Pvt Ltd



Dr Rekhapalli Srinivasa Rao

Green, Eco & Energy Lead Auditor

Certified ISO-14001 Auditor

Issued by

Rekhapalli Environmental Solutions & Technologies Pvt Ltd



December 2021



PRINCIPAL

Vignan's Institute of Management & Technology For Women
Kondapur (V), Ghatkesar (M), Medchal-Malkajiri (Dt),
Telangana State



VIGNAN'S INSTITUTE OF MANAGEMENT AND
TECHNOLOGY FOR WOMEN

Green Landscape Audit

CONTENTS

04 Acknowledgement

05 Executive Summary

07 Introduction

13 Recommendations

14 Conclusion



PRINCIPAL
Vignan's Institute of Management & Technology For Women
Kondapur (V), Ghatkesar (M), Medchal-Malkajgiri (Dt)-501301
Telangana State

Acknowledgements

REST Pvt Ltd

Dr Rekhapalli Srinivasa Rao
Green, Eco & Energy Lead Auditor
Certified ISO-14001 Auditor

20 Dec 2021

Green Landscape Audit

The REST Pvt Ltd acknowledges with thanks the cooperation extended to our team for completing the study at Vignan's Institute of Management and Technology for Women (VMTW).

The interactions and deliberations with VMTW team were exemplary and the whole exercise was thoroughly a rewarding experience for us. We deeply appreciate the interest, enthusiasm, and commitment of VMTW team towards environmental sustainability.

We are sure that the recommendations presented in this report will be implemented and the VMTW team will be further improve their environmental performance.

Kind regards

Your sincerely



Dr Rekhapalli Srinivasa Rao
Green, Eco & Energy Lead Auditor
Certified ISO-14001 Auditor
REST Pvt Ltd



PRINCIPAL 4 | Page
Vignan's Institute of Management & Technology For Women
Kondapur (V), Ghatkesar (M), Medchal-Malkajiri (Dt)-501301
Telangana State

Executive Summary

The growth of countries across the world is leading to increased consumption of natural resources. There is an urgent need to establish environmental sustainability in every activity we do. In a modern academy, environmental sustainability will play a critical role in the very existence of an organization.

An educational institution is no different. Built environment, especially an educational institution, has a considerable foot print on the environment. Impact on the environment due to energy consumption, water usage and waste generation in an educational institution is prominent. Therefore, there is an imminent need to reduce the overall environmental footprint of the institution.

As an institution of higher learning, Vignan's Institute of Management and Technology for Women (VMTW) firmly believes that there is an urgent need to address the environmental challenges and improve their environmental footprint.

True to its belief, VMTW maintain an excellent landscaping in its campus. The whole campus is lush green, and trees are seen everywhere around the campus. REST congratulates the VMTW for their efforts to create a truly green campus.

Based on the data submitted by VMTW team, following improvement opportunities have been identified in the campus in terms of landscaping.

- Implement ecosystem restoration by development of theme gardens in used areas of the campus
- Develop green corridors between existing areas in the campus
- Develop natural areas to encourage bird roosting and nesting in built-up areas
- Increase tree density and canopy cover in the built-up areas by planting more fruit yielding trees.
- Conduct regular flora surveys for improving the existing data
- Develop strategies for regular monitoring prevention of invasive plant species.



PRINCIPAL 5 | Page
Vignan's Institute of Management & Technology For Women
Kondapur (V), Ghatkesar (M), Medchal-Malkajgiri (DI)-501301
Telangana State

By addressing the improvement opportunities, the campus would be able to achieve the following benefits:

- Identifying & implementation of proper measure for conservation of endangered floral species in the campus
- Reduce the microclimate temperature of the campus by 1-2° C which is significant
- As many of the species have the capability to absorb contaminants in the air and therefore this would lead to better air quality in the campus
- This can evolve as an excellent educational campus for spreading awareness on biodiversity and benefit the nation at large.



PRINCIPAL
Vignani's Institute of Management & Technology For Women
Kondapur (V), Ghatkesar (M), Medchal-Malkajiri (Dt)-501301
Telangana State
6 | Page

Introduction

Urbanisation and its effect on loss of biodiversity

Urbanization causes biodiversity to decline. As cities grow vital habitat is destroyed or fragmented into patches not big enough to support complex ecological communities. In the city, species may become endangered or even locally extinct as natural areas are swallowed up by the urban jungle.

Ironically, it is urban growth that is often responsible for the introduction of non-native species, either accidentally or deliberately, for food, pets or for aesthetic reasons.

Documentation of Flora

Knowledge on biodiversity of any geographical region is a paramount importance for sustainable management and conservation plans. The foremost task in the conservation process is to prepare an inventory of species. It is necessary to have full knowledge regarding the habit, habitat, distribution and phenology of various plants for their proper conservation.

The documentation of flora will help in identifying, documenting and promoting the conservation of native flora in India. This in turn will help in promoting native species for landscapes as they suit one growing interest in "Low maintenance" gardening and landscaping.

Many species are vigorous & hard and can survive winter, cold, and summer heat. These species once established, can flourish without irrigation or fertilization and are resistant to most pests & diseases.

Need for documentation of Flora

The knowledge building on significance and importance of various flora existing around us is the need of the hour. Loss of the biodiversity is likely to result in loss of various other taxonomic groups.

Serve as a ready reckoner:

Most of the campuses have huge landscape with diverse floral species. Nevertheless, the availability of information on these species is minimal. Hence, the documentation of the species would serve as an educational material on the details of species existing within the campus.



PRINCIPAL
Vignans Institute of Management & Technology For Women
Kondapur (V), Ghatkesar (M), Medchal-Malkajgiri (Dt)-501301
Telangana State

Public Visibility:

Despite having various biodiversity initiatives in place within the campus most of the campuses lack the visibility of the measures taken in conservation. The study will create awareness & visibility of the campus on various conservation measures implemented to the occupants as well as to the visitors.

Also, the organization will gain globally amongst its shareholders for the positive steps taken towards protecting biodiversity.

Conservation of Species:

Due to Urbanization most of the floral species are under tremendous pressure. The need of the hour is to conserve and protect these species. The study would help in identifying such species in the campus which need to be conserved.



PRINCIPAL
Vignan's Institute of Management & Technology For Women
Kondapur (V), Ghatkesar (M), Medchal-Malkajgiri (Dt)-501301
Telangana State

VMTW carbon sequestration through plantation

Carbon sequestration through plantation is one of the important steps towards achieving carbon neutrality. In carbon footprint calculation of VMTW, carbon sequestration through plantation is considered and due credit has been given.

No. of trees considered for carbon footprint calculation	: 128trees
CO2 absorbed by a tree in one year	: 18 kg
Total CO2 sequestered	: 128trees x 18 kg of CO2/year
	: 2304 kgs of CO2
	: 2.3 tonnes of CO2



Vignani
PRINCIPAL
Vignani's Institute of Management & Technology For Women
Kondapur (V), Ghatkesar (M), Medchal-Malkajigiri (Dt)-501301
Telangana State



Vignans
PRINCIPAL
Vignans Institute of Management & Technology For Women
Kondapur (V), Ghatkesar (M), Medchal-Malkajgiri (Dt)-501301
Telangana State

Plantation & Maintenance techniques

Selection of species

- Native species like *Azadirachta indica* (Neem), *Pongamia pinnata* (Pongam tree), *Cassia fistula* (Indian shower tree), *Butea monosperma* (Flame of the forest) and also fruit bearing species like *Mangifera indica* (Mango), *Manilkara sapota* (Chikoo), *Syzygium cumini* (Jamun Tree), *Psidium guajva* (Guava), *Annona squamosa* (Custard apple), *Punica granatum* (Pomegranate), *Phyllanthus emblica* (Indian Gooseberry), *Citrus sinensis* (Sweet lime) and *Citrus limon* (Lime) to be selected for plantation. Neem, Mango, Palm, Areka palm, Purple heart plant, Spanish cherry, *Strelitzia Nicolai* and Other Trees already planted in VMTW.
- Saplings of 2-3 ft height to be considered for plantation in public areas.
- Plantation can be taken up as avenues (roadside plantation) and green belts (thick plantation in one area).
- Fruit plantation can be taken up in protected areas, institutions with large areas. Special care to be taken in maintenance since these plants also generate revenue.

Digging of pits

Pits to be dug about one month prior to the plantation date and it should be exposed to sunlight

This will help in killing of harmful disease-causing bacteria and virus.

1. In places of no availability of proper sunlight, dry trash to be filled in the pit and burnt.
2. Pit size should be normally 2ft or 3ft and in soils which are very hard 4ft³ or above to be dug.
3. Further to the digging of pit, the bottom of the pit should be loosened up to 6-9 inches.
4. While digging, we can observe different soil profiles. Topsoil will be soft and contains enough nutrients for nourishing the plant. The topsoil should be deposited on one end and hard soil on the other end. While filling the pit with soil, the topsoil only should be used. The topsoil from the non-plantation area around the pit to be collected and mixed with manure and used for filling of the pit.



PRINCIPAL
Vignans Institute of Management & Technology For Women
Kondapur (V), Ghatkesar (M), Medchal-Malkajgiri (Dt)-501301
Telangana State

Transportation

- Visit to the nurseries and enquire about plant species like availability, size, age and girth prior to the plantation. Also, the size of the packet in which the plant is existing to be enquired.
- Ensure that the material is available in the nursery and allotted to pick up
- The saplings to be watered one or two days prior to the movement of plants to plantation area
- The plants to be procured at least 15 days prior to plantation.
 - The saplings to be watered as soon as they reach the plantation area and regularly thereafter.
 - They should be kept in shade, non-windy & protected areas.

The above said steps to be followed for movement of plants near to the pits within the plantation area. Enough water to be stored for watering the plants after plantation. Also, tools and manpower to be kept in place to ensure proper plantation of saplings. If the sapling is bushy with many branches, then the branches are to be trimmed before plantation.

Plantation

- The poly bag around the root ball to be carefully cut with a knife / sickle / scissors without disturbing the roots
- Rope and stakes are to be kept ready to support the plant after plantation.
- Regular watering to be done to the plants followed by mulching (loosening of top 3-4 inches of soil)
- Mulching will help in conservation of moisture, aeration of roots and control of weeds.
- Note: At least 5% of extra plants to be procured for timely gap filling and to ensure 100% survival. Care to be taken for these plants like other plants.



PRINCIPAL
Vignans Institute of Management & Technology For Women
Kondapur (V), Ghatkesar (M), Medchal-Malkajgiri (Dt)-501301
Telangana State

Recommendations for Enhancing Flora in Campus

1. Implement Ecosystem Restoration

- Develop naturalised areas in the Open Area segments
 - Wastelands in the campus can be converted to a park
- 'Theme Gardens' can be developed in unused areas of the campus to increase proportion of natural area

2. Enhance Ecosystem Protection

- Protect and maintain the existing Open Area segments

3. Planting more fruit yielding trees

- Increase tree density and canopy cover in the built-up areas

4. Increase number of Native Plants in the Landscape area

- Increase native plants to boost native biodiversity
 - Bees, butterflies and other insects
- Healthy native plant growth will help in easy identification of invasive alien species

5. Introduce more native species in Open Areas

6. Preventing/ Decreasing Invasive Alien Species Spread

- Identify potential threatening species in advance and implement quarantine measures
- Mass Eradication techniques for larger spreads
- Commitment to complete eradication
- Manual Uprooting of small populations

7. Develop natural areas to encourage bird roosting and nesting in built-up areas

8. Introduce features to attract birds in the built-up areas

- Bird feeders
- Water troughs/ Bird baths
- Nesting material

9. Improve measures for rainwater harvesting in paved and un-paved areas

- Open fields, parks, pavement landscapes, etc.
- Develop outdoor parks in open areas



PRINCIPAL
Vignani's Institute of Management & Technology For Women
Kondapur (V), Ghatkesar (M), Medchal-Malkajgiri (Dt)-501301
Telangana State

Conclusion

As seen in the carbon sequestration calculation, tree plantations lead to a tremendous reduction in net emissions of the campus. Therefore, VMTW needs to develop a roadmap to include tree plantation as a strategy to reduce overall carbon emissions of the campus.

Two or three small ponds may be developed in the campus for aquatic plants and water source of campus birds.

More Biodiversity conservation and preservation methods are suggested and University may apply for a branding or ranking w.r.t. its biodiversity.

Water ponds in the form of Rain water cum Roof water harvesting ponds should be developed and it will improve aquatic biodiversity also.

Heritage trees identified must be well preserved and protected taking it as a pride and privilege. It develops a strong sense of love, respect and reverence to the visitors of the campus.



PRINCIPAL
Vignans Institute of Management & Technology For Women
Kondapur (V), Ghatkesar (M), Medchal-Malkajiri (Dt)-501301
Telangana State

CERTIFICATE OF COMPLETION

This is to certify that

Vignan's Institute of Management and Technology for Women

has successfully completed

GREEN LAND SCAPE AUDIT

The study was completed by Rekhapalli Environmental Solutions & Technologies Pvt Ltd



Dr Rekhapalli Srinivasa Rao

*Green, Eco & Energy Lead Auditor
Certified ISO-14001 Auditor*

Issued by

Rekhapalli Environmental Solutions & Technologies Pvt Ltd



December 2021



PRINCIPAL

Vignan's Institute of Management & Technology For Women
Kondapur (V), Ghatkesar (M), Medchal-Malkajiri (Dt) - 501301
Telangana State



VIGNAN'S INSTITUTE OF MANAGEMENT AND
TECHNOLOGY FOR WOMEN

Carbon Footprint and Energy Audit

CONTENTS

04 Acknowledgement

05 Executive Summary

07 Carbon footprint & Opportunities

11 Energy efficiency

17 Conclusion

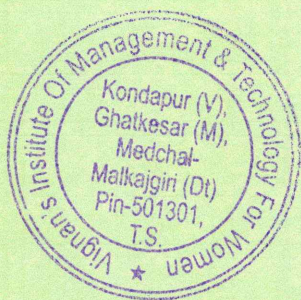

PRINCIPAL

Vignan's Institute of Management & Technology For Women
Kondapur (V), Ghatkesar (M), Medchal-Malkajiri (Dt)-501301
Telangana State

Acknowledgements

REST Pvt Ltd

Dr Rekhapalli Srinivasa Rao
Green, Eco & Energy Lead Auditor
Certified ISO-14001 Auditor

20 Dec 2021

Carbon Footprint & Energy Audit

The REST Pvt Ltd acknowledges with thanks the cooperation extended to our team for completing the study at Vignan's Institute of Management and Technology for Women (VMTW)

The interactions and deliberations with VMTW team were exemplary and the whole exercise was thoroughly a rewarding experience for us. We deeply appreciate the interest, enthusiasm, and commitment of VMTW team towards environmental sustainability.

We are sure that the recommendations presented in this report will be implemented and the VMTW team will be further improve their environmental performance.

Kind regards

Your sincerely



Dr Rekhapalli Srinivasa Rao

Green, Eco & Energy Lead Auditor
Certified ISO-14001 Auditor
REST Pvt Ltd

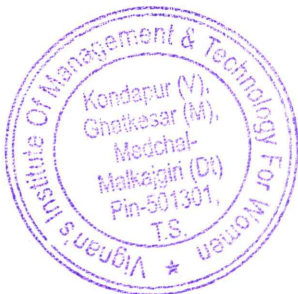

PRINCIPAL

Vignan's Institute of Management & Technology For Women
Kondapur (V), Ghatkesar (M), Medchal-Malkajgiri (DI)-501301
Telangana State

Executive Summary

The growth of countries across the world is leading to increased consumption of natural resources. There is an urgent need to establish environmental sustainability in every activity we do. In a modern economy, environmental sustainability will play a critical role in the very existence of an organization.

An educational institution is no different. Built environment, especially an educational institution, has a considerable footprint on the environment. Impact on the environment due to energy consumption, water usage and waste generation in an educational institute is prominent. Therefore, there is an imminent need to reduce the overall environmental footprint of the institution.

As an Institution of higher learning, West Godavari Institute of Science & Engineering (VMTW) firmly believes that there is an urgent need to address the environmental challenges and improve their environmental footprint.

True to its belief, VMTW has almost 70% transforming conventional bulbs & fixtures into non-conventional energy LEDs. REST Pvt Ltd team congratulates VMTW team for their efforts.

Keeping VMTW work in energy efficiency, we recommend the following to be taken by the competent team at VMTW:

Work towards achieving carbon neutrality: NDC emphasizes creating an additional carbon sink of 2.5 to 3 billion tonnes of CO² equivalent through additional forest and tree cover by 2030. VMTW's net carbon emission for the year 2020-21 is 107 MT CO²e. VMTW should focus on energy efficiency, renewable energy, and carbon sequestration as tools that will enable them to offset the present carbon emissions and achieve carbon neutrality.

Installation of solar rooftop: Renewable energy plays a very important role in improving the environmental footprint of an organization. By increasing the share of renewable energy in VMTW's energy portfolio, the overall carbon footprint of the college can be reduced. The roof area available at VMTW is around 83129.68 sq.ft. As an initial step, VMTW could look at installing 25kWp of solar PV which can generate 40,500 units per year. Still the renewable share will also reduce the 140 MT CO²e. For the current assessment year power consumption is 50454 units/year. Still another 100kWp of roof top can be utilized for solar power to expand in step VMTW.

Increase the operating power factor: Presently, based on the energy bills, it is understood that the institution maintains a power factor of 0.65. Since the institution pays electricity bills for the KVAH consumed, the lower the power factor, higher is the energy bill for the same KWH consumption. It is recommended to install capacitor banks to improve the power factor and save energy bill. VMTW can save up to Rs. 20,000 per month.

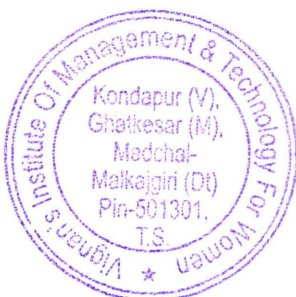

5 | Page

PRINCIPAL

Vignani's Institute of Management & Technology For Women
Kondapur (V), Ghatkesar (M), Medchal-Malkajgiri (DI)-501301
Telangana State

Improve energy efficiency of the college: It is recommended to adopt latest energy efficient technologies for reducing energy consumption in fans, lighting, and air conditioners. We recommend the following projects to be implemented at the earliest:

- Replace conventional 60W ceiling fans with energy efficient BLDC fans of 30W
- Install air conditioners energy savers to save energy in split air conditioners
- Replace all conventional tube lights with LED lamps



PRINCIPAL

Vignan's Institute of Management & Technology For Women
Kondapur (V), Ghatkesar (M), Medchal-Malkajgiri (DI) District
Telangana State

Carbon Footprint and Energy Audit

Vignan's Institute of Management and Technology for Women (VMTW) and REST Pvt Ltd are working together to identify opportunities for improvement in energy efficiency and carbon reduction. This report highlights all the potential proposals for improvement through the audit and analysis of the data provided by VMTW for lighting, air conditioning, ceiling fans, and biogas potential.

The report also details the carbon emissions from college operations. For carbon emissions, scope 1 and scope 2 emissions are calculated from the data submitted by VMTW. The report emphasizes the GHG emission reduction potential possible through a reduction in power consumption.

Effect of pandemic and online classes on energy consumption and carbon footprint:

The year 2020-21 was affected by the pandemic and because of the pandemic, most of the classes were shifted online. There has been a steady in the consumption of energy in the year 2020-21 around 50454kWH.

Submission of Documents

"Carbon footprint and energy audit at VMTW was carried out with the help of data submitted by VMTW team. VMTW team was responsible for collecting all the necessary data and submitting the relevant documents to REST Pvt Ltd for the study.

Note

Carbon footprint and energy audit are based on the data provided by VMTW team and discussions the REST Pvt Ltd team had with VMTW team. The scope of the study does not include the exclusive verification of various regulatory requirements related to environmental sustainability.

REST Pvt Ltd has the right to recall the study if it finds (a) major violation in meeting the environmental regulatory requirements by the location and (b) occurrence of major accidents, leading to significant damage to ecology and environment.



PRINCIPAL
Vignan's Institute of Management & Technology For Women
Kondapur (V), Ghatkesar (M), Medchal-Malkajgiri (DI)-501301
Telangana State

Opportunities for improvement

As a part of the overall environmental improvement study at VMTW, carbon footprint calculations were also carried out. The objective of calculating the carbon footprint of the campus is find the present level of emissions from campus operation and what initiatives that the VMTW can take to offset the emissions. By offsetting the emissions, the college can become carbon neutral in the future by adopting energy efficient processes, increase in renewable energy share and tree plantation.

Carbon footprint calculations:

To help delineate direct and indirect emission sources, improve transparency, and provide utility for different types of organizations and different types of climate policies and business goals, three "scopes" (scope 1, scope 2, and scope 3) are defined for GHG accounting and reporting purposes.

For calculating carbon footprint of the campus, Scope 1 & Scope 2 emissions are being considered. Since day scholars use college provided transportation and hostellers stay in campus, Scope 1 and Scope 2 are the highest contributor to overall emissions. For this reason, Scope 3 is not being calculated.

Scope 1: Direct GHG Emissions

Direct GHG emissions occur from sources that are owned or controlled by the company, for example, emissions from combustion in owned or controlled DG sets, canteen, vehicles, etc.; emissions from chemical production in owned or controlled process equipment. Direct CO2 emissions from the combustion of biomass shall not be included in scope 1 but reported separately.

VMTW Scope 1 emissions for 2020-21:

Sources of Scope 1 emissions in VMTW:

- 1) Diesel consumption for the generator for the assessment year 2020-21 is 22,627 litres/yr.
- 2) LPG used for canteen/Lab: 240 cylinders/year

Scope 2: Electricity Indirect GHG Emissions

Scope 2 accounts for GHG emissions from the generation of purchased electricity consumed by a college. Purchased electricity is defined as electricity that is purchased or other VMTW brought into the organizational boundary of the college. Scope 2 emissions physically occur at the facility where electricity is generated.

VMTW Scope 2 emissions for 2021: Electricity purchased from grid: 50454Units

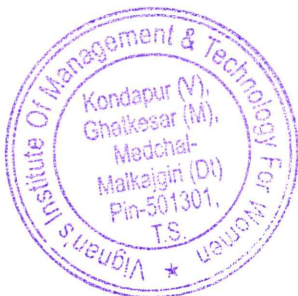

PRINCIPAL

8 | Page

Vignans Institute of Management & Technology For Women
Kondapur (V), Ghatkesar (M), Medchal-Malkajgiri (DI)-501301
Telangana State

Develop a roadmap to increase contribution of renewable energy in the overall energy consumption

To have a continued focus on increasing renewable energy utilization to 100% which will also lead to reduction in GHG emissions, it is suggested to develop a detailed roadmap on RE utilization. The road map should broadly feature the following aspects -

- Renewable energy potential of VMTW and the maximum offset that can be achieved at VMTW
- Percentage substitution with renewable energy that VMTW wants to achieve in a specified time frame

Key tasks that need to be executed to achieve the renewable energy target

- Specific financial break up for each of the projects highlighting the amount required, available and the utilization status as on date
- A regular review mechanism to ensure progress along the lines of the roadmap should be framed
- The roadmap should also highlight important milestones/key tasks, anticipated bottle VMTW & proposed

Renewable energy roadmap should be used as a base to frame GHG emissions reduction target

It is suggested to use the developed renewable energy roadmap to correlate the GHG reduction that each of the renewable energy project will achieve. This approach will provide a base to set targets for reduction in GHG emissions. The action plan for renewable energy will shoulder the action plan for GHG emissions reduction and work towards achieving carbon neutrality.

Explore the option of other onsite and offsite renewable energy projects

The renewable energy field has been witnessing many private investors due its increased market demand and attractive policies in many states. There are Renewable Energy Independent Power Producers (RE IPPs) who have installed RE based power plants like wind, small hydro and solar PV. GOC can consider having a long-term power purchase agreement with these RE IPPs in purchasing fixed quantity of power for a period of 5 to 10 years.

"Evolve a system to monitor the implementation of various GHG mitigation opportunities VMTW has an action plan to reduce its GHG emissions. VMTW should also evolve a system to monitor the implementation of various GHG mitigation opportunities. It is recommended to use a Gantt chart to mark out the action plan for the activities and track its implementation. Gantt chart will serve as an excellent way to instantly monitor and comprehend all different tasks in one place which would ease tracking of implementation.

Calculation for Installation of 25 kWp of Solar PV in VMTW campus

Renewable energy is one of the important steps to be taken up by the college to reduce their overall carbon footprint. Based on the details provided by VMTW team, the roof area available at VMTW is around 83129.68 sq.ft. As an initial step, VMTW could look at installing 25kWp of solar PV which can generate 40,500 units per year. Still the renewable share will also reduce the 140 MT CO²e. For the current assessment year power consumption is 50454 units/year. Still another

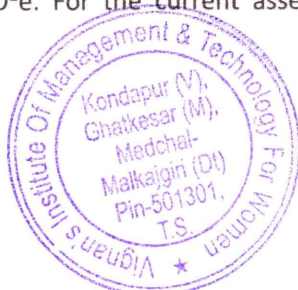

9 | Page

PRINCIPAL
Vignans Institute of Management & Technology For Women
Kondapur (V), Chatkesar (M), Medchal-Malkajgiri (DI)-501301
Telangana State

100kWp of roof top can be utilized for solar power to expand in stepVMTW. However, for this report calculation, only 25 kWp capacity is considered.

A renewable energy capacity of 25 kW of solar panel may be installed can generate 40,500 units of electricity per year. Additionally, 25 kWp of solar rooftop can offset 33 MT CO₂e per annum. RESCO model for solar rooftop installation:

A Renewable Energy Service Company (RESCO) is an ESCO Energy service company which provides energy to the consumers from renewable energy sources. RESCO or BOOT model is about pay as Ju consume the electricity.

- Solar Power Plant is owned by the RESCO or Energy Company
- Customer must sign a Power purchase Agreement (PPA) with actual investor at mutually agreed tariff and tenure
- Customer only pays for electricity consumed
- RESCO developer is responsible for its annual operations & maintenance (O&M)
- The RESCO gets the benefit by selling the surplus power generated to the DISCOM

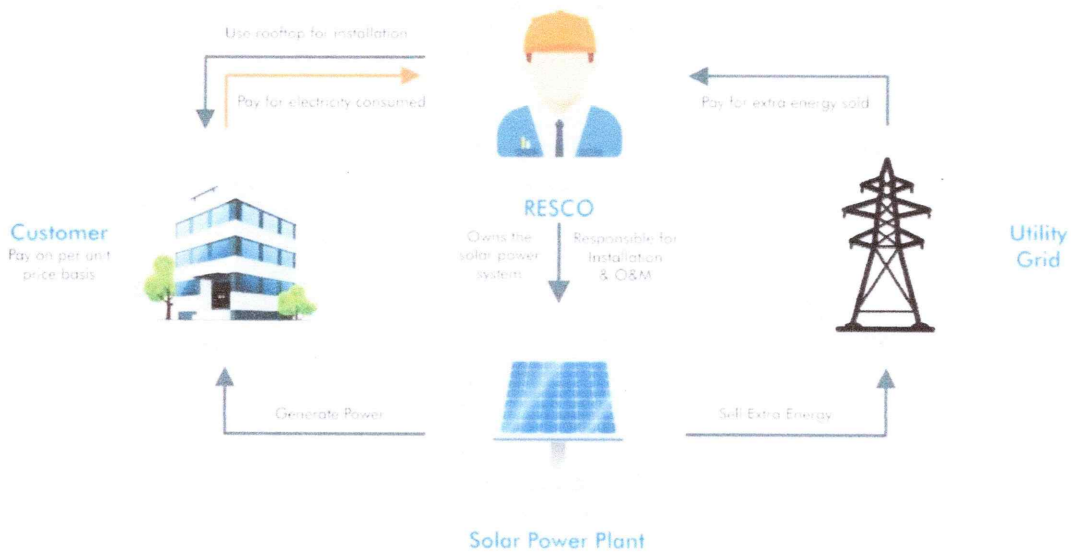

Source: www.bluebirdsolar.com



[Handwritten Signature]

PRINCIPAL

Vignani's Institute of Management & Technology For Women
Kondapur (V), Ghatkesar (M), Medchal-Malkajiri (Dt)-501301
Telangana State

Energy Efficiency

Annual energy consumption of VMTW campus is 50454 units. There are major blocks in the campus which consumes energy for their operation. Major energy consumers are:

1. Fans
2. Air conditioners

Replace conventional tube lights with LED lamps

Replace Conventional Ceiling Fans with Energy Efficient BLDC Fans

During the Energy Audit at VMTW, a detailed study was carried out to identify the potential for replacing the existing ceiling fans with BLDC super fans. There are 287 fans operating in VMTW campus.

Instead of conventional ceiling fans, latest technology BLDC fans which consume only 30W can be installed in the newly constructed building. A brushless DC (BLDC) motor is a synchronous electric motor powered by direct-current (DC) electricity and having an electronic commutation system, rather than a mechanical commutator and brushes. A BLDC motor has an external armature called the stator, and an internal armature called the rotor.

The rotor can usually be a permanent magnet. Typical BLDC motor-based ceiling fan has much better efficiency and excellent constant RPM control as it operates out of fixed DC voltage. The proposed BLDC motor and the control electronics operate out of 24V DC through an SMPS having input AC which can vary from 90V to 270V. The operational block diagram of a BLDC motor is as follows:

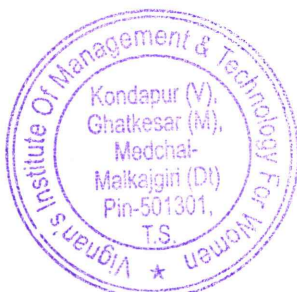
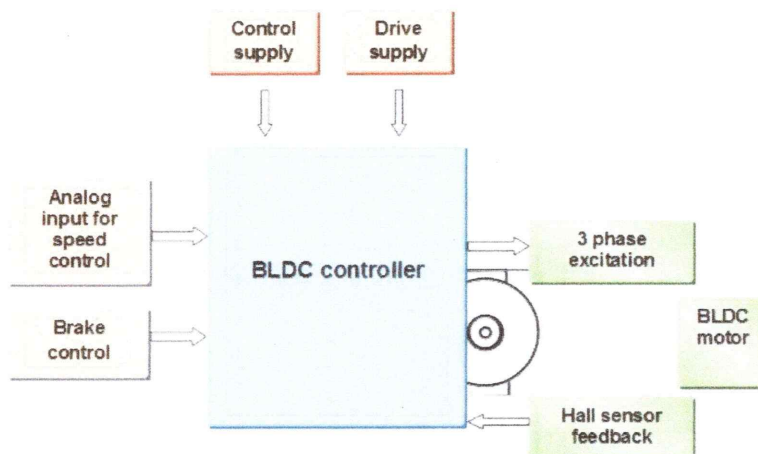

PRINCIPAL
Vignans Institute of Management & Technology For Women
Kondapur (V), Ghatkesar (M), Medchal-Malkajgiri (DI)-501301
Telangana State

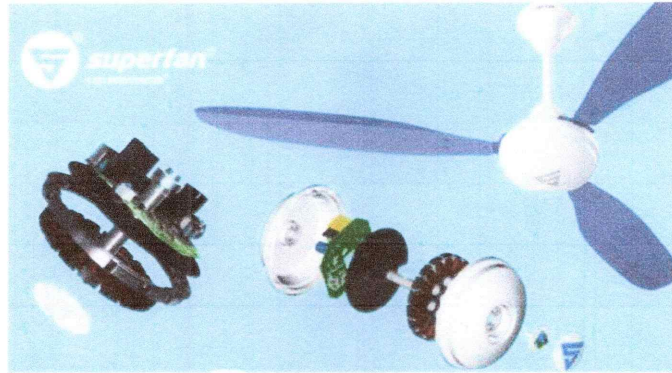

With the replacement of existing ceiling fans with Super Fans the energy consumption is likely to reduce by 55% per fan. Considering 100 fans being replaced with super-efficient BLDC fans, 3.50 kW can be saved. Considering the average operating hours to be 2000 and unit cost as Rs.

7.50, the calculations are as follows:

Total no. of fans in college	:	287
No. of fans considered for calculation	:	100 (First cycle of change)
Energy consumption per fan	:	60W
Total energy consumption of fans	:	60W X 100 fans
	:	6 kW
super-efficient BLDC fans energy consumption:	:	30 W
Savings from 60W to 30 W	:	50%
Total savings in fans energy consumption	:	50% of 6kW
	:	3 kW
Savings per year	:	3kW x 2000 hrs X Rs. 7.50/unit
	:	Rs. 0.45 Lakhs
Investment	:	Rs. 2, 50,000
	:	5.5 months
Annual emission reduction potential	:	6.00 T CO2



 PRINCIPAL
 Vignan's Institute of Management & Technology For Women
 Kondapur (V), Ghatkesar (M), Medchal-Malkajiri (Dt)-501301
 Telangana State

Install Air conditioners energy saver for spilt air conditioners:

Present status: As per the data obtained from VMTW team, the campus has majorly 1.5 TR units installed. There are 23 spilt air conditioners installed.

Recommendation:

We recommend installing "Airtron", an energy saver that can be installed at every individual unit of AC. The Airtron is the world's most advanced AC SAVER, with all the controls of a Precision AC. The Airtron's dual sensors reference the Room and Coil & Ambient Temp, and uses complex, multiple algorithms in a "closed-loop circuit" to reduce the Compressor Run-Time, to ensure the high savings while maintaining and displaying the Set temperature accurately. The Airtron is Programmable for geographical location and climate and adapts automatically to changes in season and ambient conditions.

This unique device has been developed on Patent-Published technology and approved by leading MNC'S, PSU'S and Govt. Departments. The Airtron is validated by EESL (Energy Efficiency Services Ltd.), Ministry of Power, Government of India, for 44% savings. The Airtron has been validated on all AC's- Inverters, 5 Star, Splits, Multi-Splits, Packages, ducts, Windows, Cassettes from 1.0 - 20.0 TR, LG Ltd, Videocon Ltd, Tata Communications, L&T, Nestle, Ashok Leyland etc. The AIRTRON comes with a Remote for setting the Room Temperature, and in a Non-Flammable Polycarbonate Enclosure, with SMPS Power Supply, to tolerate wide Voltage and Current fluctuations, Surges, Spikes and Sags.

In our case, Airtron installation can reduce the energy consumption of each fixture by 15% on a conservative basis. For a total energy consumption, for air conditioners, as 20 units per hour, 3 units per hour can be saved. It is recommended to install Airtron energy saver in a phase VMTW manner preferably in the batches of 10 units.

Saving Calculation: Considering the operating hours to be 2000 and unit cost as Rs 7.50/-.

- Monetary annual savings : Rs 45,000/-
- Total investment : Rs 80,000/-
- Payback period : 22 months (2 years)
- Annual emission reduction potential: 4.92 MT CO2

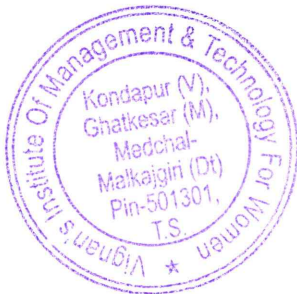

[Handwritten Signature]
PRINCIPAL
Vignan's Institute of Management & Technology For Women
Kondapur (V), Ghatkesar (M), Medchal-Malkajgiri (Dt) - 501301
Telangana State

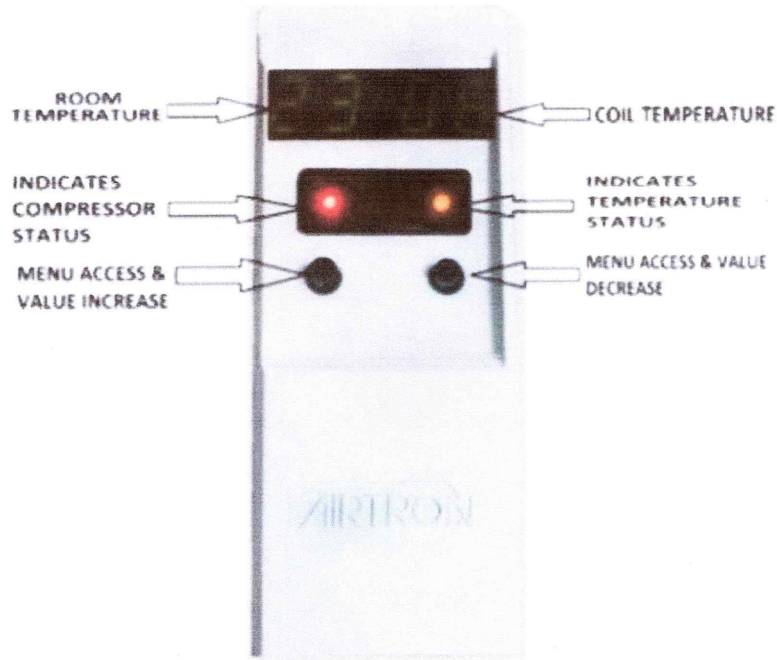

Replace Conventional Lamps with LED Lamps

As per the data submitted, the total number of all the lighting fixtures installed are

- 1. LED Tube Lights : 190x20watts = 3,800Watts
- 2. Normal tube lights : 73 x 36watts = 2,628 Watts
- 3. LED bulbs : 04x22Watts = 88Watts
- 4. Normal bulbs : 0

Under failure replacement policy, at least 130 lamps can be changed in the first year.

Types of fixtures	36W Tube
No of fixtures	130
No of hours in Operation	2000



 14 | Page
PRINCIPAL
 Vignans Institute of Management & Technology For Women
 Kondapur (V), Ghatkesar (M), Medchal-Malkajgiri (Dt)-501301
 Telangana State

The campus should be keen in harnessing the day lighting available thereby reducing the use of artificial lighting.

Based on the occupancy, monitoring should be ensured to reduce excessive consumption of energy.

Major savings in energy through lighting fixtures can be achieved by replacing all the above existing fixtures with LED's meeting the required LUX levels. The LED's being less energy consuming while maintaining the equivalent lux is the more sustainable option. The replacement of lighting fixtures should be done as per failure replacement policy i.e. change the old fixture with LED when it fails

Advantages of LED

- **Lower energy consumption:** The energy consumption of LEDs is low when compared to the other conventional sources for the same amount of Lumen output.

Performance comparison of different type lights

Type of Lamp	Lumen/Watt	CRI	Life hours
HPSV lamps	90-120	Bad (22-25)	15,000-20,000
Metal Halide lamps	65-100	Good (65-90)	18,000
LED lamps	100-150	Very Good (>80)	10,000-12,000

- **High S/P ratio:** LEDs have higher scotopic/photopic ratio (S/P ratio). The eye has two primary light sensing cells called rods and cones - cones function in day light and process visual information whereas rods function in night light. The cone dominated vision is called photopic and the rod dominated vision is called scotopic. The S/P ratio indicates the measure of light that excites rods compared to the light that excites cones. In office environments, illumination is more effective if the S/P ratio is high as it is under scotopic region. LEDs hence are ideally suited for these applications as they have a high S/P ratio.
- **Longer life-time:** LEDs have longer life time of around 1,00,000 hours. This is equivalent to 11years of continuous operation or 22 years of 50% operation.
- **Faster switching:** LED lights reach its brightness instantly upon switching and can frequently be switched on/off without reducing the operational life expectancy.



15 | Page
PRINCIPAL
Vignans Institute of Management & Technology For Women
Kondapur (V), Ghatkesar (M), Medchal-Malkajiri (Dt)-501301
Telangana State

- **Greater durability and reliability:** As LEDs are solid-state devices and uses semi-conductor material; they are sturdier than conventional sources that use filaments or glass. LEDs can also withstand shock, extreme temperatures and vibration as they don't have fragile materials as components.
- **Good Colour Rendering Index (CRI):** The colour rendering index, i.e., measure of a light sources' ability to show objects as perceived under sunlight is high for LEDs. The CRI of natural sunlight is 100 and LEDs offer CRI of 80 and above.

LED offers more focused light and reduced glare. Moreover, it does not contain pollutants like mercury. LED technology is highly compatible for solar lighting as low-voltage power supply is enough for LED illumination.

Calculations are as follows:

Existing Lighting fixtures	36W
Existing power consumption(kW)	4.5kW (130lamps)
Proposed LED wattage (W)	15
LED power consumption (kW)	1.95kW
Energy saving (kW)	2.55kW
Operating hours	2000

Annual monetary savings : Rs 38,250/-
 Investment needed : Rs 90,000/-
 Payback period : 2.5 years
 Annual Emission reduction potential : 4.18MT of CO2.



[Signature]
 PRINCIPAL
 Vignar's Institute of Management & Technology For Women
 Kondapur (V), Ghatkesar (M), Medchal-Malkajgiri (Dt)-501301
 Telangana State

Conclusion

VMTW has initiated few energy efficiency activities in their campus. While REST Pvt Ltd appreciates the VMTW team for their efforts, we would like to emphasize that opportunity exists further reduce the energy consumption. Installation of renewable energy is to be given major focus. RESCO model can be adopted to install renewable energy without upfront capital investment. We in REST Pvt Ltd are sure that all the recommendations mentioned in the report will be implemented by VMTW team and the overall environmental performance of the campus will be improved.

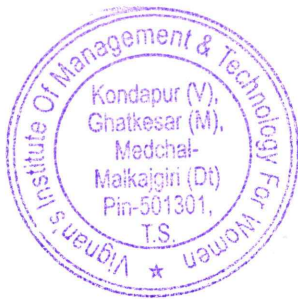

PRINCIPAL

Vignans Institute of Management & Technology For Women
Kondapur (V), Ghatkesar (M), Medchal-Malkajgiri (Dt),
Telangana State

CERTIFICATE OF COMPLETION

This is to certify that

Vignan's Institute of Management and Technology for
Women

has successfully completed

CARBON FOOTPRINT & ENERGY AUDIT

The study was completed by Rekhapalli Environmental Solutions &
Technologies Pvt Ltd



Dr Rekhapalli Srinivasa Rao

Green, Eco & Energy Lead Auditor
Certified ISO-14001 Auditor

Issued by

Rekhapalli Environmental Solutions & Technologies Pvt Ltd



December 2021



PRINCIPAL

Vignan's Institute of Management & Technology For Women
Kondapur (V), Ghatkesar (M), Medchal-Malkajgiri (D)-501301
Telangana State